

Industrial oil chillers

COOLING CAPACITY

2300-2700 - 3600-4200 W



STRUCTURE

In powder-coated steel sheet, RAL 7035 textured finish. Easily removed panels

COMPRESSOR

Hermetic scroll compressor, cooled by the refrigerant, complete with thermal cut-out.

REFRIGERATION CIRCUIT

Complete with charging port, liquid receiver, drier filter, thermostatic valve, high- and low-pressure pressure switch, R410A refrigerant. Stepped cooling power regulation - 2 steps standard / 4 steps optional (standard on TALO6).

EVAPORATOR

Brazed stainless-steel plate model.

AIR CONDENSER

Microchannel condensing coil, complete with safety grille.

AXIAL FAN

Axial fan, complete with thermal cut-out and safety grille.

LIQUID CIRCUIT

Non-ferrous liquid circuit composed

of stainless steel centrifugal electric pump, storage tank made of plastic material complete with drain valve, electrical level indicator, 0-10 bar pressure gauge, differential pressure switch protecting the water flow, automatic by-pass and regulation sensor.

ELECTRICAL PANEL

With main disconnect switch, relay motor protection, phase sequence relays.

MANAGEMENT AND CONTROL

The TX350C control unit manages the operation of the chiller and provides complete operator alarm diagnostics. An on-off contact allows the machine to be switched on remotely. Illuminated control selector. RS485 connection. Possibility of remote display for machine regulation.

PAINT/COATING

Standard colour: RAL 7035 textured.

MAIN OPTIONS

FL - Flow switch with alarm contact

HR - Fluid heating element

OM - Unit built for outdoor operation down to -10 °C ambient temp.

OML - Unit built for outdoor operation down to -20 °C ambient temp.

FP - Polyurethane air filter

TD - Differential fluid temperature management (two sensors)

BGC - Hot gas bypass for +/- 1 K temperature precision

LS - Liquid circuit for laser application

- HIGH-pressure pump version "H" - 5 bar

DIMENSIONS

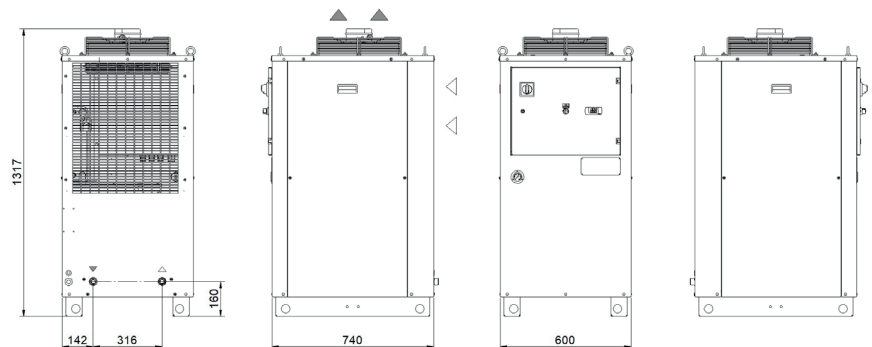

Model		TAO24		TAO37	
		50Hz	60Hz	50Hz	60Hz
Rated Cooling Capacity*	W	2300	2700	3600	4200
Ambient temperature operating limits	°C	+15 - +45			
Settable fluid temperature range	°C	+25 - +40			
Fluid type		ISO VG 32			
Temperature precision	K	+/-2			
Refrigerant gas	HFC	R134a			
Power supply					
Supply voltage	V ph Hz	230V (+/-10%) 1ph 50/60Hz			
Secondary supply voltage	V	230 V AC			
Digital thermostat		TX110			
Compressor					
Compressor type		Reciprocating			
Quantity - Number of circuits	no.	1 - 1			
Nominal power draw	kW	0.84	1.04	1.16	1.5
Axial Fan					
Fan type		Axial			
Quantity	no.	1			
Air flow rate	m ³ /h	1250 - 1650		1550 - 2050	
Centrifugal Fan (optional)					
Fan type		Centrifugal			
Quantity	no.	1			
Air flow rate	m ³ /h	2100 - 2400		2100 - 2400	
Available head	Pa	250			
Standard Pump					
Pump type		Gear pump			
Quantity	no.	1			
Nominal/max fluid flow rate	l/min	10		20	
Nominal available head	bar	10		10	
Storage tank capacity (optional)					
Storage tank capacity (optional)	l	50			
IN/OUT liquid connections	inch	3/4"			
Net weight (approximate)***	kg	151		153	
Width - Depth - Height	mm	600 - 740 - 1317			
Height with tank and pump	mm	1790			
Sound pressure level**	dB(A)	57	60	57	60
<p>* Data relates to operation under the following conditions: inlet/outlet oil temp. 40/30°C, ISO VG 32 oil, ambient temperature 32°C.</p> <p>** Sound pressure level, measured in a free parallelepiped field at a distance of 1 m, per ISO 3746.</p> <p>*** Weight includes pallets and packaging (where provided for), with refrigerant charge, without storage tank and axial fans.</p> <p>The electrical data refer to cos φ = 0.8.</p>					

Correction factors for calculating the cooling power												
Oil outlet temperature	Fo	°C	20	25	30	35						
		factor	0.59	0.77	1	1.22						
Ambient Temperature	Fa	°C				15	20	25	32	35	40	45
		factor				1.26	1.2	1.11	1	0.95	0.87	0.80
Oil type	Ft	type	ISO VG 10		ISO VG 22		ISO VG 32		ISO VG 46		ISO VG 68	
		factor	1.15		1.1		1		0.9		0.82	
Cooling power = Nominal cooling power x Fo x Fa x Ft												